



REALEDZ LIGHTING CO., LIMITED

Shenzhen ReaLEDz Technology Co., Ltd.

ADD: Bldg. E, Shifeng Industrial Park, Huaning Road, Dalang Street, Bao'an District, Shenzhen, Guangdong, China

Tel:0086-755-23000505

Fax:0086-755-23311530

<http://www.realedz.com>

Mobile:15361557996

Contact:Elsa

Email:sales@realedz.com

Skype:elsa1618

Specification of LED Panel Light



Model No: RL-SPL60120





REALEDZ LIGHTING CO., LIMITED

Shenzhen ReaLEDz Technology Co., Ltd.

ADD: Bldg. E, Shifeng Industrial Park, Huaning Road, Dalang Street, Bao'an District, Shenzhen, Guangdong, China

Tel:0086-755-23000505

Fax:0086-755-23311530

<http://www.realedz.com>

Mobile:15361557996

Contact:Elsa

Email:sales@realedz.com

Skype:elsa1618

Contents

1. Product Description	2
2. Application	2
3. Technical Parameter	3
4. Dimension	4
5. Luminous Distribution Diagram	5
6. Illuminance Diagram	6
7. LED Life Prediction	6
8. Package	7
9. Installation Method	8
10. Attention on Installation	10
11. Notes on using	10
12. Maintenance Suggestion	10



REALEDZ LIGHTING CO., LIMITED

Shenzhen ReaLEDz Technology Co., Ltd.

ADD: Bldg. E, Shifeng Industrial Park, Huaning Road, Dalang Street, Bao'an District, Shenzhen, Guangdong, China

Tel:0086-755-23000505

Fax:0086-755-23311530

<http://www.realedz.com>

Mobile:15361557996

Contact:Elsa

Email:sales@realedz.com

Skype:elsa1618

Introduction:

LED panel light is a brand new product which is based on LED Light for commercial lighting and home lighting. With unique design, LED panel light can be hanged on the roof or mounted to the walls or on the surface of other objects. It is also great for decorative lighting.

ReaLEDz LED panel Light is a perfect replacement for traditional fluorescence tubes that are often used with suspended ceilings. LED panel light utilizes the high power LED for practical solution to general overhead room and office lighting.

Features:

- Super slim design, save 70% energy, High efficiency 80LM/W with uniformed luminance.
- Life span: 50000 hours
- Wide range of input voltage: AC100-277V
- Instant start, no noise, no flickering
- New high efficiency constant current driver.
- Professional circuit design, each group of LEDs work separately to avoid any problem of lighting output caused by single faulty LED.
- No electrical wave interference, confirm to the standard of CE.
- No plumbum, green environment friendly, confirm to the standard of RoHS.
- No RF interference.

Application: Hotel, Shopping Mall, Exhibition Hall, Offices, Conference Room, Schools, Universities,
Airport Station, Hospital, School, Factory, etc.



REALEDZ LIGHTING CO., LIMITED

Shenzhen ReaLEDz Technology Co., Ltd.

ADD: Bldg. E, Shifeng Industrial Park, Huaning Road, Dalang Street, Bao'an District, Shenzhen, Guangdong, China

Tel:0086-755-23000505

Fax:0086-755-23311530

http://www.realedz.com

Mobile:15361557996

Contact:Elsa

Email:sales@realedz.com

Skype:elsa1618

Technical Parameter

No	Parameter		
01	Input Voltage	AC 100-277V(UL) AC100-240V(CE)	
02	Working Voltage	≤36V	
03	Input Power	□54W	□72W □90W
04	Luminous	□54W <u>4100</u> lm	□72W <u>5400</u> lm □90W <u>7200</u> lm
05	Power Efficiency	□54W <u>75</u> lm/w	□72W <u>75</u> lm/w □90W <u>80</u> lm/w
06	Color	Up to request	
07	Color Temp	□WW / Warm White 2800-3500K □W / White 5000-5500K	□NW / Natural White 4000-4500K □CW / Cool White 6000-6500K
08	CRI	3014 ≥72 5630 ≥80	
09	LED Qty	3014	□54W <u>528</u> PCS □72W <u>704</u> PCS
		5630	□54W <u>176</u> PCS □72W <u>176</u> PCS □90W <u>198</u> PCS
10	LED Type	□Samsung 5630 □LumenMax 3014	
11	Life Span	50000 Hours	
12	Working Temp	-20°C — 50°C	
13	Storage Temp	-20°C — 60°C	
14	Net Weight	9.5 Kg	
15	Gross Weight	10.7 Kg	
16	IP	IP 40	



REALEDZ LIGHTING CO., LIMITED

Shenzhen ReaLEDz Technology Co., Ltd.

ADD: Bldg. E, Shifeng Industrial Park, Huanning Road, Dalang Street, Bao'an District, Shenzhen, Guangdong, China

Tel:0086-755-23000505

Fax:0086-755-23311530

<http://www.realedz.com>

Mobile:15361557996

Contact:Elsa

Email:sales@realedz.com

Skype:elsa1618

Product Dimension:

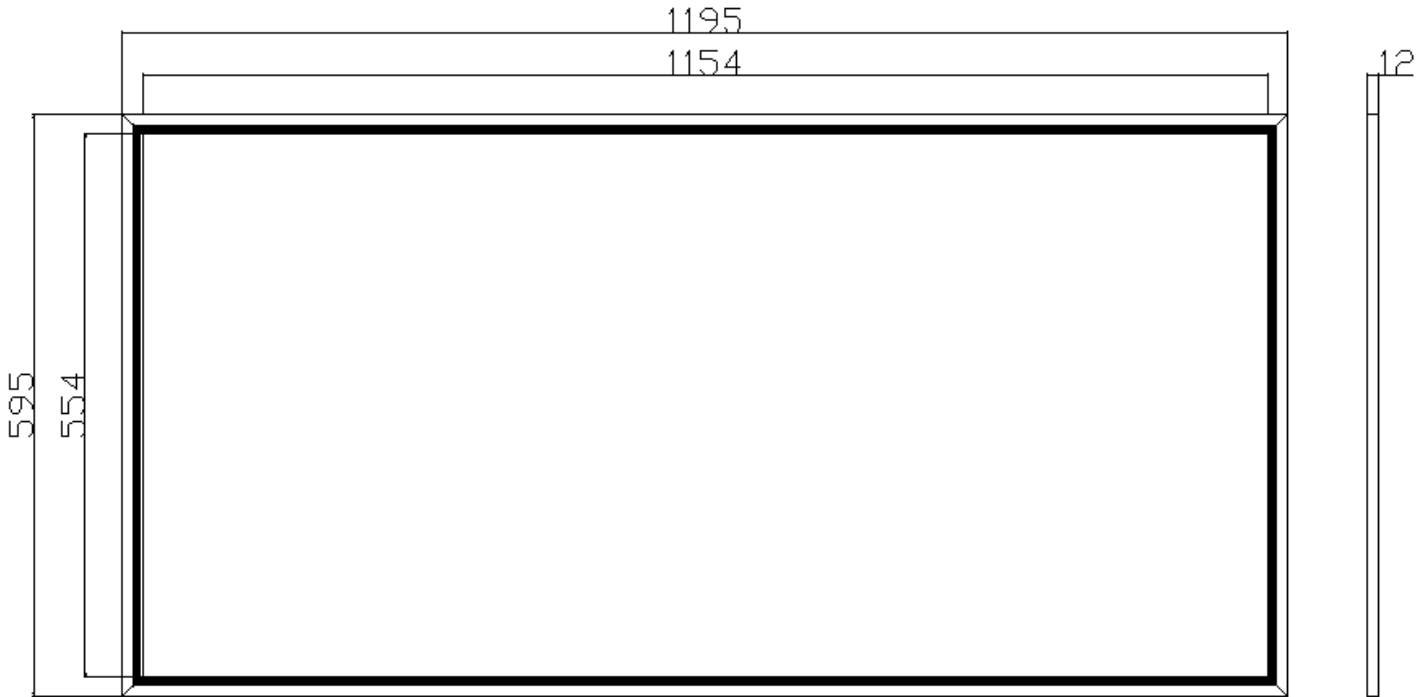

Remarks:

1. The above dimension are based on "mm"
2. There is a tolerance about $\pm 0.5\text{mm}$

Luminous Distribution Diagram:

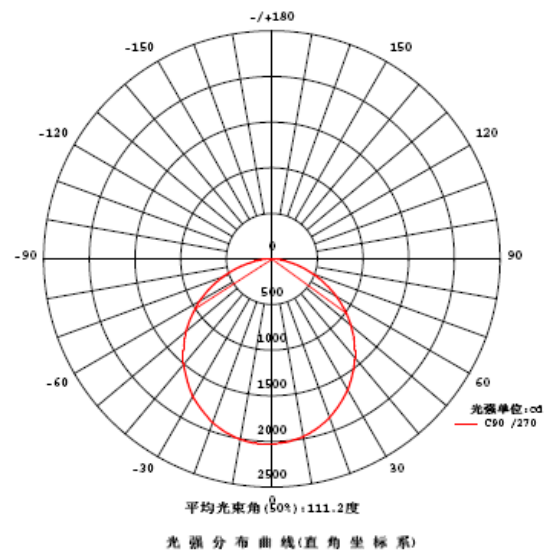
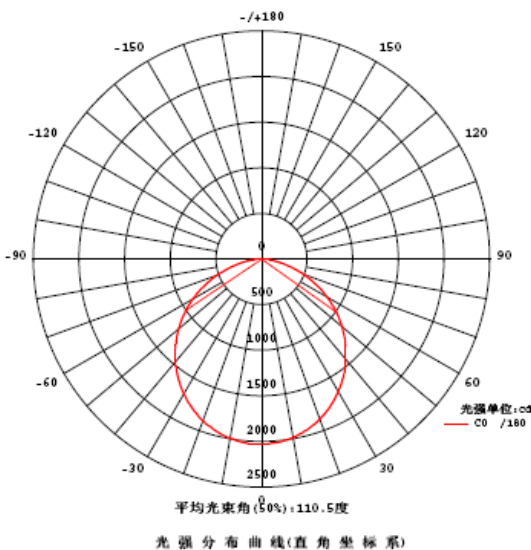



REALEDZ LIGHTING CO., LIMITED

Shenzhen ReaLEDz Technology Co., Ltd.

ADD: Bldg. E, Shifeng Industrial Park, Huaning Road, Dalang Street, Bao'an District, Shenzhen, Guangdong, China

Tel:0086-755-23000505

Fax:0086-755-23311530

http://www.realedz.com

Mobile:15361557996

Contact:Elsa

Email:sales@realedz.com

Skype:elsa1618

Illuminance Diagram

Distance		Central Illuminance		
1m		1714	2028	2359
1.5 m		786	1089	1406
2m		428	506	598
2.5 m		273	313	353
3m		190	225	265
Power		54W	72W	90W

LED Life Prediction

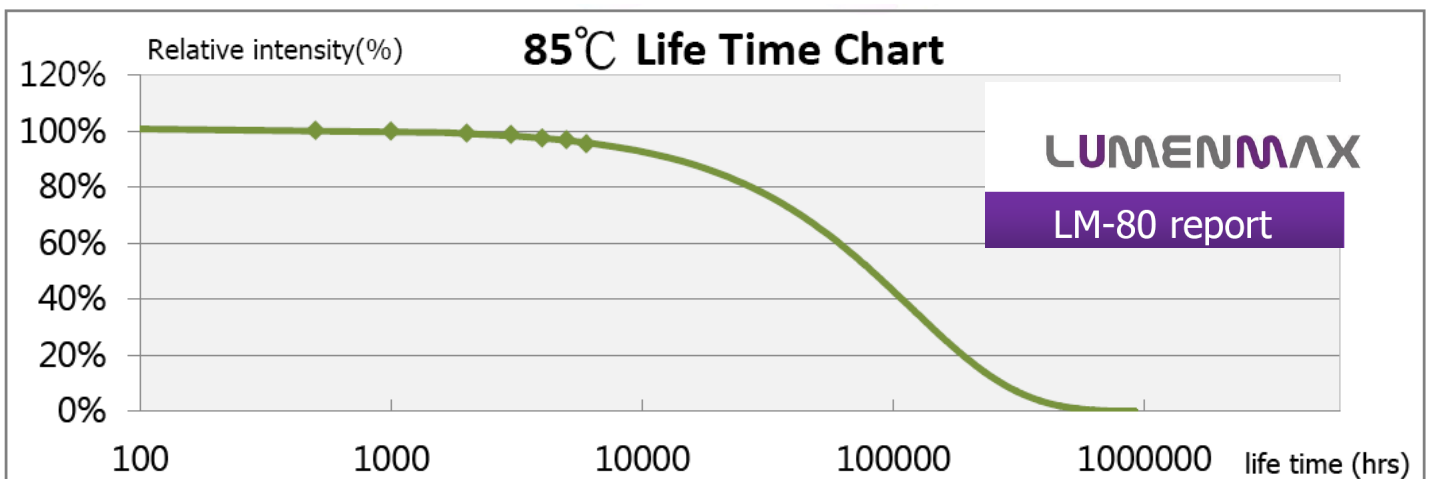



REALEDZ LIGHTING CO., LIMITED

Shenzhen ReaLEDz Technology Co., Ltd.

ADD: Bldg. E, Shifeng Industrial Park, Huaning Road, Dalang Street, Bao'an District, Shenzhen, Guangdong, China

Tel:0086-755-23000505

Fax:0086-755-23311530

<http://www.realedz.com>

Mobile:15361557996

Contact:Elsa

Email:sales@realedz.com

Skype:elsa1618

Samsung MP56L CRI70+ Test Result in our lab

[Condition : 100mA, 85°C]

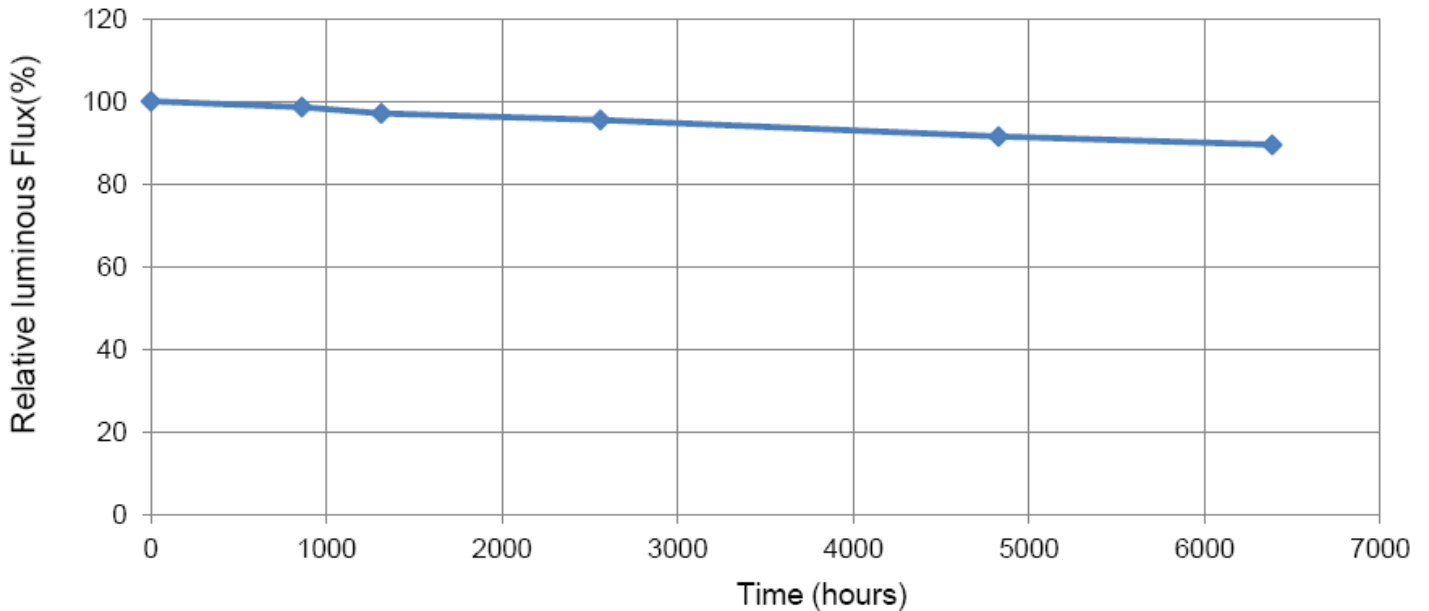

Package:

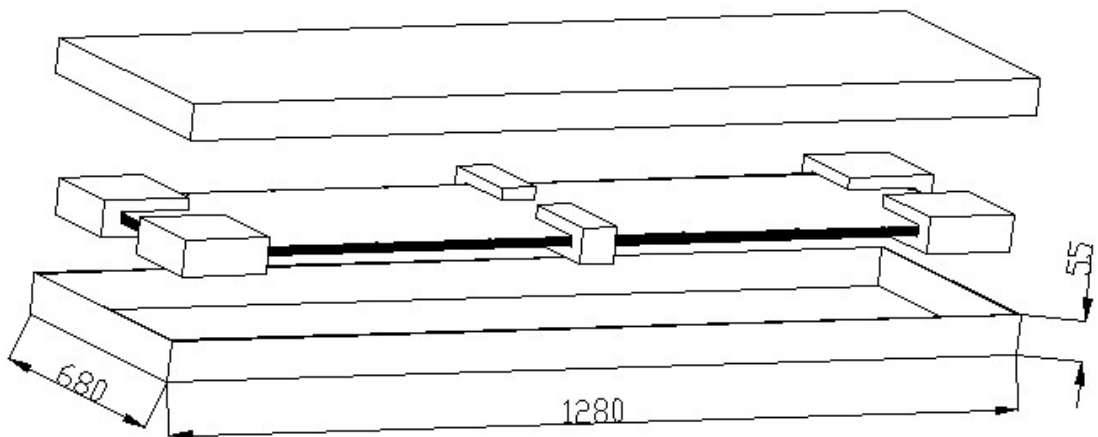



REALEDZ LIGHTING CO., LIMITED

Shenzhen ReaLEDz Technology Co., Ltd.

ADD: Bldg. E, Shifeng Industrial Park, Huaning Road, Dalang Street, Bao'an District, Shenzhen, Guangdong, China

Tel:0086-755-23000505

Fax:0086-755-23311530

<http://www.realedz.com>

Mobile:15361557996

Contact:Elsa

Email:sales@realedz.com

Skype:elsa1618

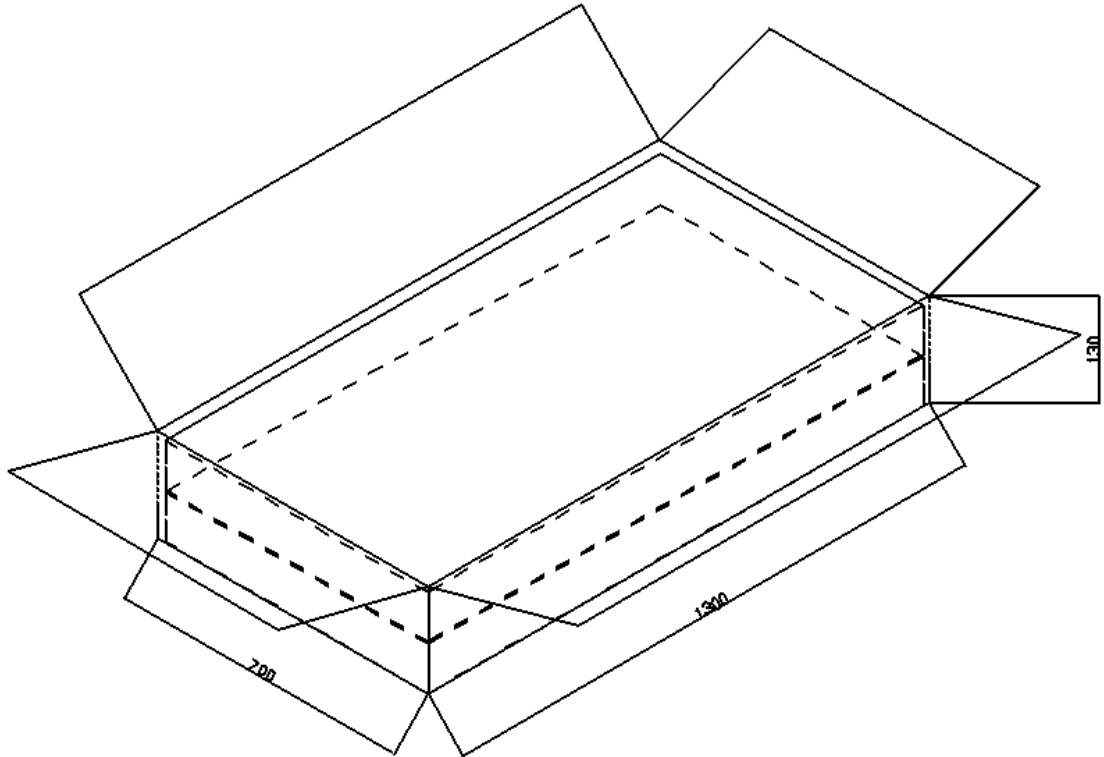

Packing Size:

Inner Box: 1280×680×55mm (1pc/box)

Net Weight: 9.5 KG

Gross Weight: 10.7KG

Outer Carton: 1300×700×130mm (2boxes/carton)

Net Weight: 21.4KG

Gross Weight: 24 KG

2 boxes packed in a Carton

Installation Method:

1. Recessed

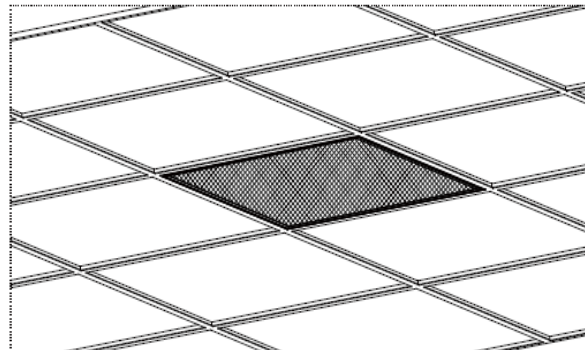
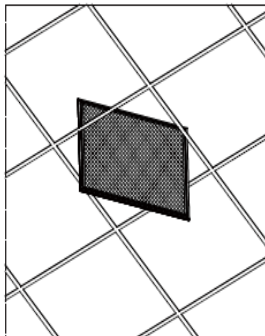

2. Ceiling Mounted

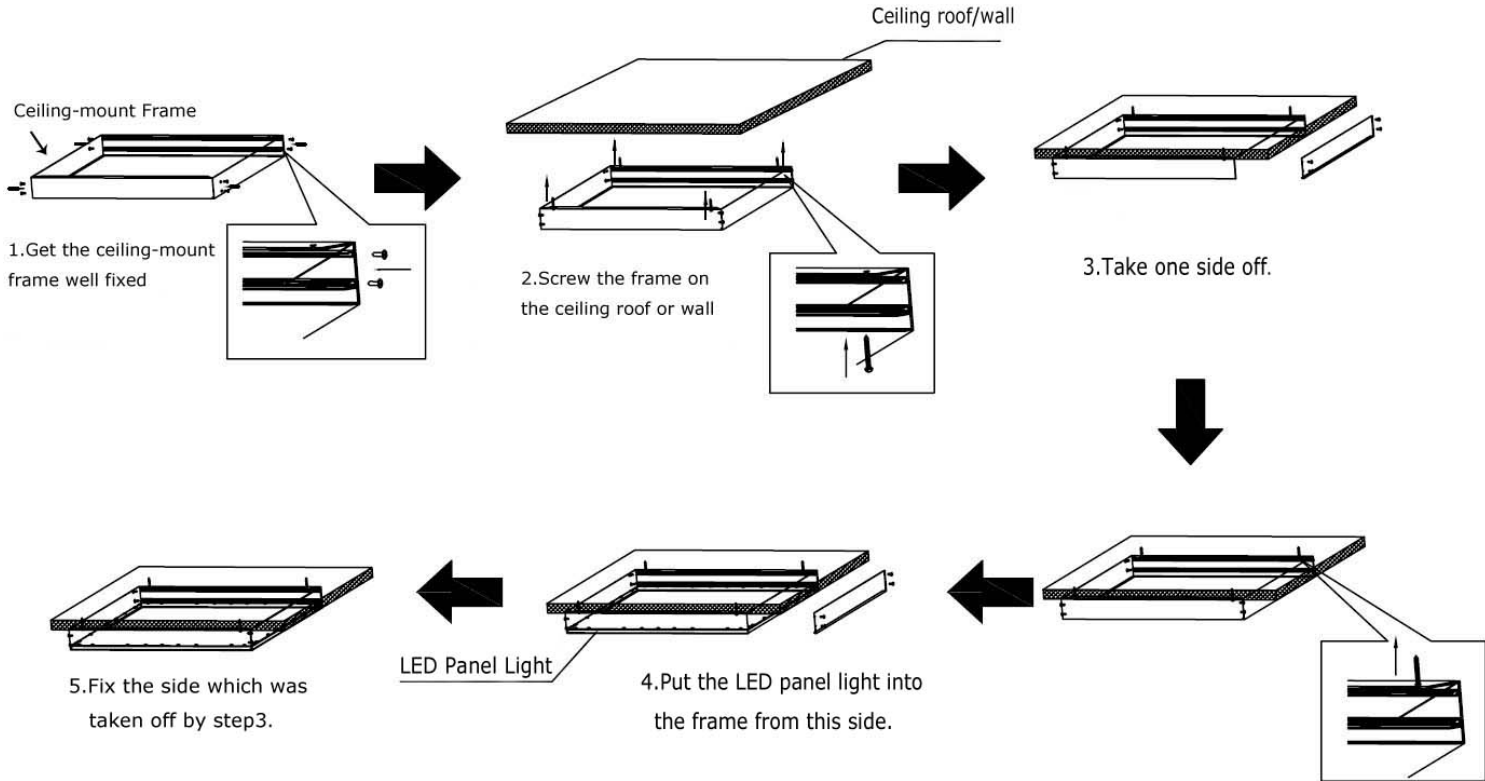

3. Suspended

B. Suspended type

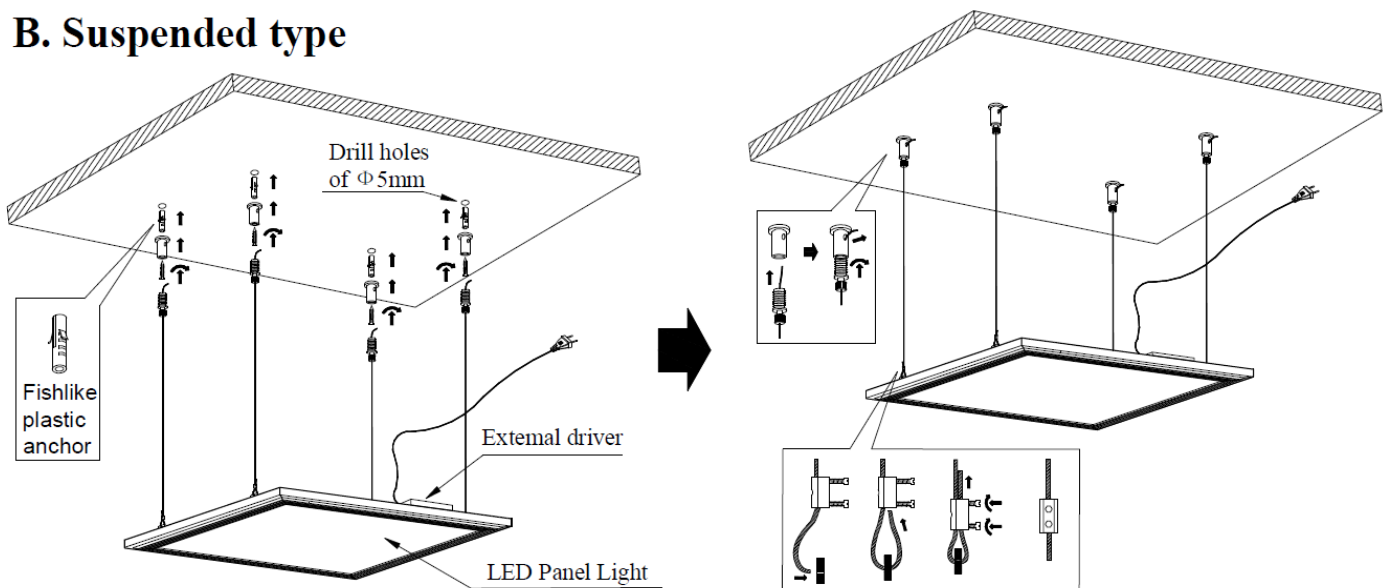



REALEDZ LIGHTING CO., LIMITED

Shenzhen ReaLEDz Technology Co., Ltd.

ADD: Bldg. E, Shifeng Industrial Park, Huaning Road, Dalang Street, Bao'an District, Shenzhen, Guangdong, China

Tel:0086-755-23000505

Fax:0086-755-23311530

<http://www.realedz.com>

Mobile:15361557996

Contact:Elsa

Email:sales@realedz.com

Skype:elsa1618

Attention on Installation:

1. Panel lights should be installed by trained electronic technician.
2. Please check all the accessories when open the cartons.
3. The distance between the light and any flammable materials must be more than 0.2m. The distance between the upper part of the installed light and the ceiling must not be less than 2 cm. Don not install into ceilings or walls that contain heat source. The main cable must not connect with the low voltage cable or the surface-mounted lights.
4. Guide the lights' connecting cables through the drilled hole, and fix the surface-mounted lights with the pre-fitted clips. Make sure that these are securely connected to the base material.
5. When laying the cables, make sure that the cables and plugs are not subjected to any tensile or twisting forces. Do not kink cables. Output cables should be laid separately and at a distance from other cables.
6. After installation, connect the transformer to the mains supply
7. Proceed by connecting the wiring cables to the lights. Usually, the brown (or black) wire is the Live wire, connect it with the terminal marked "L". The blue wire is Naughty wire; connect it with the terminal marked "N".
8. Use the dedicated LED drivers only, do not connect to other loads
9. Do not remove the label of the lights and drivers.

Notes on Using:

1. Please always use the light out of its package.
2. Before starting use of the light, please check if the light was damaged during transportation. If any damage shown, please DO not install or use it.
3. Any maintenance should be performed by trained professionals only.
4. Keep packaging material away from the reach of children and pets.
5. Caution: Keep children away from the lights, there are some small components that may be swallowed by children, and never allow them to play with electronical devices.
6. Try to avoid looking directly at lights for a long time. Do not shine the LED light in another person's eyes.
7. Never cover the lights by other objects
8. Keep the panel light away from the flames or heat sources.
9. The lights should be inspected repaired or special treatment if beyond service time.
10. Non-professionals are not allowed to disassemble and maintain the products. We have the right not to provide after-sale service if unauthorized disassembly and maintenance happens to the products.

Maintenance:

1. Before to clearing the panel lights, please make sure it have been powered OFF.
2. Use a dry or slightly moistened cloth for cleaning.
3. Never use any chemicals or abrasives for cleaning.